

HEPA

When changing motor, **DO NOT** over-tighten screws to the point of closing off the air space. Check with a piece of wire or paper clip to make sure there is an opening.

NO.	QUANTITY	UTILITY HEPA VACUUM	
		PART #	DESCRIPTION
1	1	2107	Toggle Switch
2	7	1009	S.S. Lock Nut
	6	1046	Cap Nut
	6	1047	#10 Lock Washer
	6	1049	10-24 Nut
	6	1050	#10 Nylon Washer
3	6	1007	S.S. Machine Screw
4	1	2042	Gasket (850-1050)
	1	2152	Gasket (1300)
5	1	2050	Vac Motor (850)
	1	2051	Vac Motor (1050)
	1	2055	Vac Motor (1300)
8	1	2146	Filter Cage
9	1	1051, 1052	3/8" Bolt and Nylon Washer
10	1	1031	7-3/8" Washer
11	1	1007	S.S. Machine Screw
13	1	2057	Gasket (850-1050)
	1	2040	Gasket (1300)
14	1	2025	Bottom Spinning
15	1	2323	Outside Spinning
16	1	2024	Motor Spinning (850-1050)
	1	2024A	Motor Spinning (1300)
17	3	1006	Speed Nut
18	1	2120	Top Spinning
19	2	1004	1/4" Screw
20	2	1005	1/4" Nut
21	1	2121	Top Handle
22	1	2043	Top Gasket (850-1050)
	1	2041	Top Gasket (1300)
24	1	1029	Wire Connector
25	1	2039	Gasket
26	1	2028	Strain Relief and Nut
27	1	2144	25 Foot Power Cord
28	3	1048	1-1/2" Tapping Screw (1300)
	3	1016	1-1/4" Tapping Screw (1050)
	3	1022	1" Tapping Screw (850)
29	1	4030	Hepa Filter
*30	3	1034	3/8" Spacer (850-1300)
	3	1035	5/8" Spacer (1050-1300)

* 1300 uses 3 of each

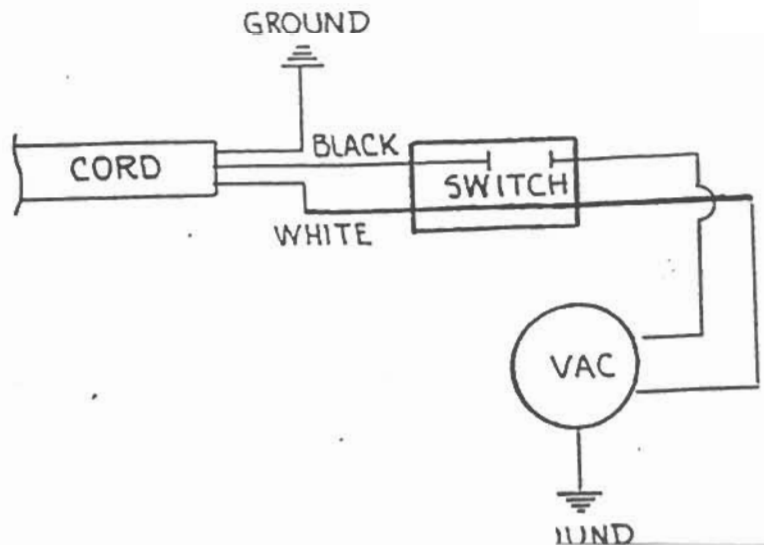

HEPA

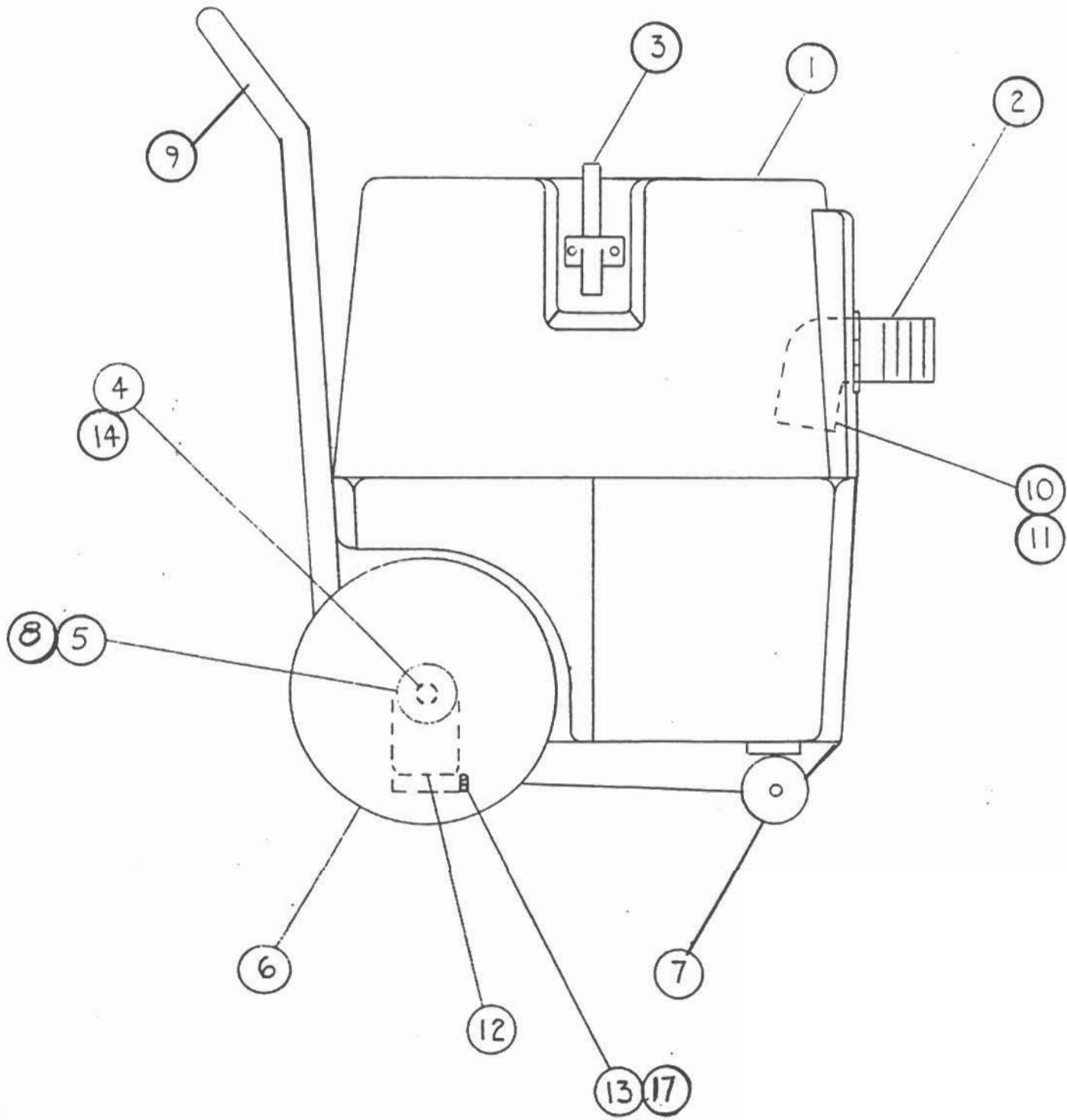

H.E.P.A. Vacuum

Item	Qty	Part#	Description
1	1	2010 <i>H</i>	10 Gallon Tank
	1	2015 <i>H</i>	15 Gallon Tank
2	1	2007	Intake
3	2	2006	Latch
4	1	2003	Axle 10 Tank
5	2	2004	Hub Cap
6	2	2001	8" Wheel
7	2	2002	Caster
8	2	1003	Washer- 10 Gal. only
9	1	4016	Handle
10	1	2008	Deflector Elbow
11	1	2009	Intake Gasket
12	2	2049	Handle Bracket
13	2	1027	1/4-20 x 1-3/4" Screw
14	1	2056	Axle 15 Tank
15	1	2018	Bag Ring N/S
16	1	4049	Coated Filter Bag
17	2	1020	1/4" Thick Washer

Filters Not Shown:

4013	Collector Bag 6/Pkg.
4031	Bag Protector 5 Pkg.
4032	Bag Liner 12/Pkg.